

4E2052

4E2052

B.Tech. (Sem.IV) (Main/Back) Examination, June -2013
Mechanical Engineering
Machining & Machine Tools

[Time : 3 Hours]

[Total Marks : 80]

[Min. Passing Marks : 24]

Instructions to Candidates :

Attempt any five questions, selecting one question from each unit. All questions carry equal marks. Schematic diagrams must be shown wherever necessary. Any data you feel missing suitably be assumed and stated clearly. Units of quantities used/ calculated must be stated clearly.

Unit - I

1. (a) Justify "Machining is a value addition process".

[8]

(b) Derive the expression for shear angle in orthogonal cutting in terms of rake angle and chip thickness ratio. [8]

OR

1. (a) What is mean by built-up-edge (BUE)? With a neat sketch explain the formation of a BUE. Explain the conditions which promote the growth of BUE along with its consequences. [8]
- (b) What is the method generally used for measuring average chip tool interface temperature? Explain its principle with a neat sketch. [8]

Unit - II

2. (a) While drilling holes in steel plate by a 20 mm diameter HSS drill at a given feed, the tool life decreased from 40 min. to 24 min. when speed was raised from 250 rpm to 320 rpm. At what speed (rpm) the life of that drill under the same condition would be 30 min.? [8]
- (b) What are the main applications of cutting fluids? [8]

OR

2. (a) In a mild steel block, a flat surface of length 100 mm and width 60 mm has to be finished in a shaping machine in a single pass. How much machining time will be require if $N_s = 80$, $S_0 = 0.2$ mm/stroke. $A = O = 5$ mm, $QRR = 0.5$ [8]
- (b) What short note broaching operation. [8]

Unit - III

3. Prepare an operational plan and turret tool layout for the production of 2500 work pieces of following hollow bolt as shown in figure.

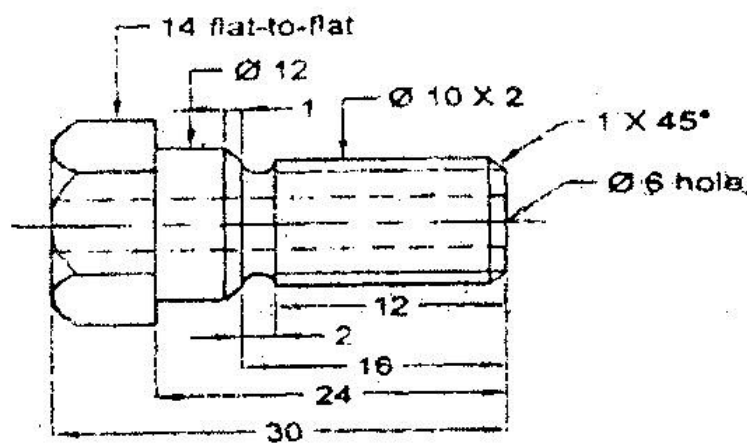

Fig.

OR

3. (a) Differentiate truing and dressing of grinding wheel? [8]
- (b) State the disadvantages of centre less cylindrical grinding machine? [8]

Unit - IV

4. (a) Which one method of threading is best for general purpose and why? [8]
- (b) Explain thread rolling with neat sketches only. [8]

OR

4. (a) What is difference between gear generation and gear forming? [8]
- (b) Explain gear hobbing method with neat sketch. [8]

Unit - V

5. Write short notes on any two from following :

- (a) High velocity forming methods.
- (b) Industrial safety methods
- (c) Difference between electro hydraulic forming and magnetic pulse forming.
- (d) Industrial noise controls [16]