

B.Tech. (Sem. VII) (Main) Examination, January - 2010
Electrical Engineering
(7EE2 Power System Analysis)

Time : 3 Hours]

[Total Marks : 80

[Min. Passing Marks : 24

Attempt overall five questions. All questions carry equal marks. (Schematic diagrams must be shown wherever necessary. Any data you feel missing may suitably be assumed and stated clearly. Units of quantities used/calculated must be stated clearly.)

Use of following supporting material is permitted during examination. (Mentioned in form No. 205)

1. _____ Nil _____

2. _____ Nil _____

1 (a) What is per unit system? How the base quantities are selected?

(b) Fig. 1 shows the one line diagram of a simple power system.

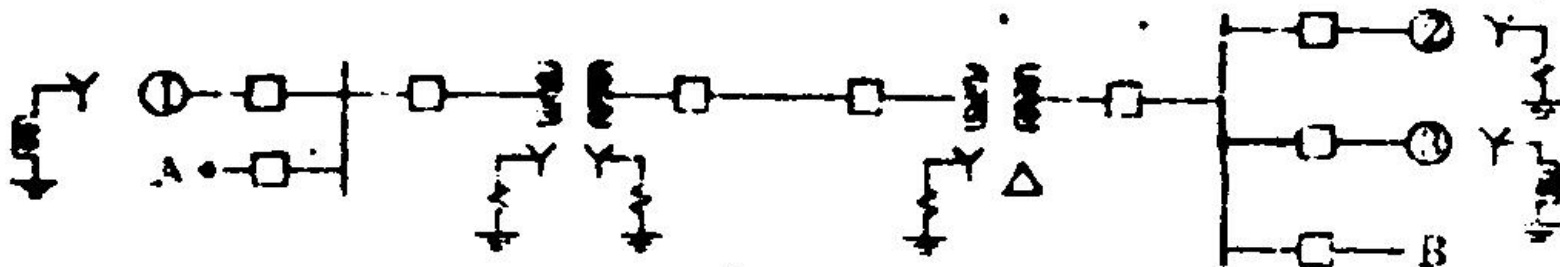

Fig. 1

One-line representation of a simple power system

Gen. No. 1	30 MVA	10.5 kV	$X'' = 1.6$ ohms
Gen. No. 2	15 MVA	6.6 kV	$X'' = 1.2$ ohms
Gen. No. 3	25 MVA	6.6 kV	$X'' = 0.56$ ohms
Transformer T ₁	15 MVA	33/11 kV	$X = 15.2$ ohms per phase on high tension side
Transformer T ₂	15 MVA 3 phase	33/6.2 kV	$X = 16$ ohms per phase on high tension side.

Transmission line 20.5 ohms/phase

Load A	40 MW	11 kV	0.9 lagging power factor
Load B	40 MW	6.6 kV	0.85 lagging power factor

10

OR

1 (a) The parameters for a 4 bus system are as under :

Bus code	Line Impedance	Changing Admittance $Y_{pi}/2$
1-2	$0.2 + j0.8$	0.02
2-3	$0.3 + j0.9$	0.03
2-4	$0.25 + j1.0$	0.04
3-4	$0.2 + j0.8$	0.02
1-3	$0.1 + j0.4$	0.01

Draw the network and find bus admittance matrix.

10

(b) Give reason that bus admittance matrix is a sparse matrix.

2

(c) Define primitive network, bus incidence and basic loop incidence matrix.

4

2 The four generator G_1 , G_2 , G_3 and G_4 are arranged in a ring bus bar as shown in fig. 2. To limit the short circuit current the reactors are interposed in between. Calculate the short ckt MVA if there is a fault at point F. All reactances are referred to their respective MVA and all the generators are solidly earthed.

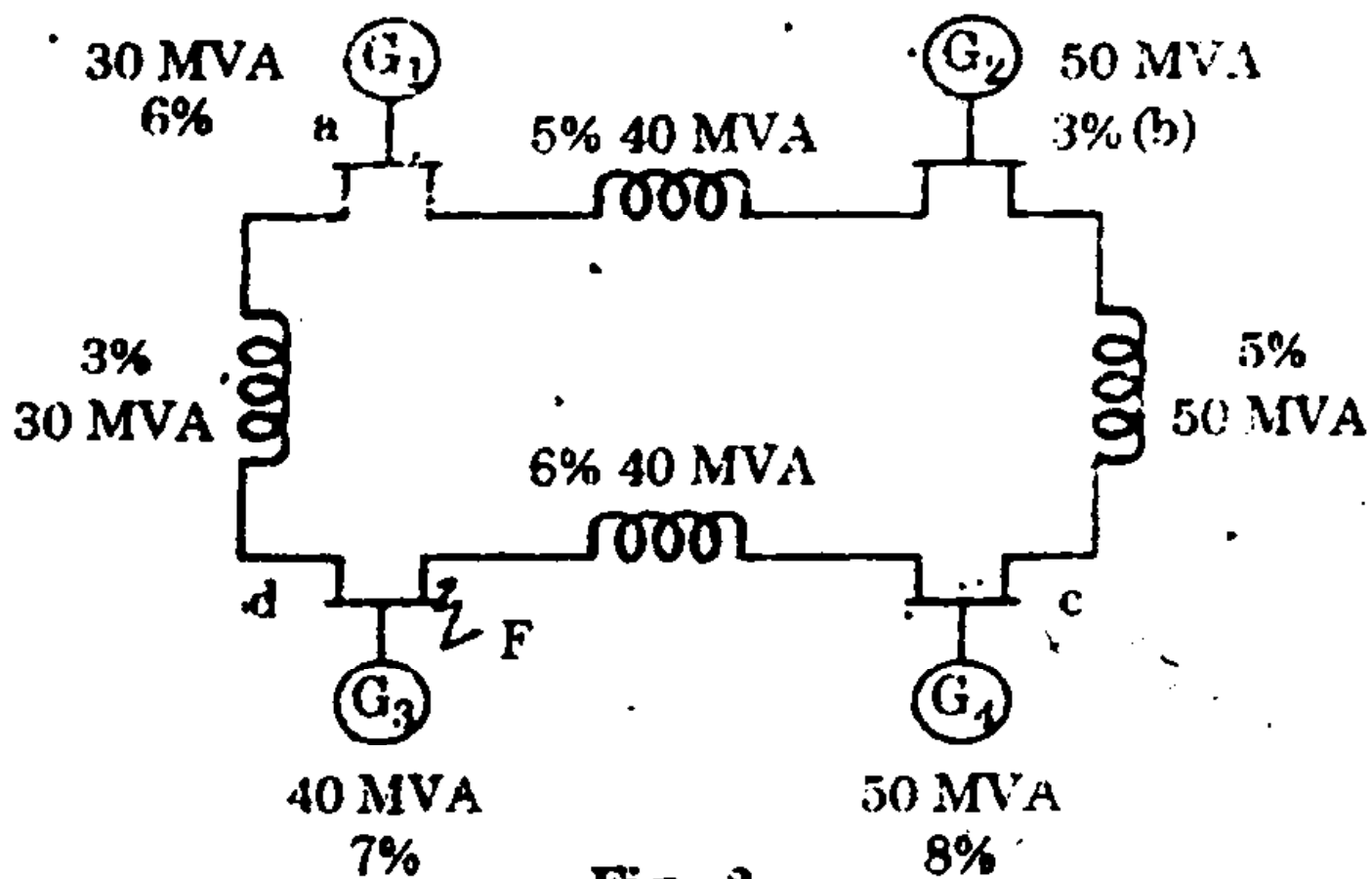

Fig. 2

16

OR

- 2 (a) Draw equivalent ckts of synchronous machine under subtransient, transient and steady state conditions.
- (b) A 3 phase transmission line operating at 10 kV and having a resistance of 1Ω and reactance of 4Ω is connected to the generating station bus-bars through 5 MVA step-up transformer having a reactance of 3%. The bus-bars are supplied by a 10 MVA alternator having 10% reactance. Calculate the short ckt. kVA fed to symmetrical fault between phases if it occurs reactance. Calculate the short-circuit kVA fed to symmetrical fault between phases if it occurs.
- (c) at the load end to transmission line
- (d) at the high voltage terminals of the Xmer.

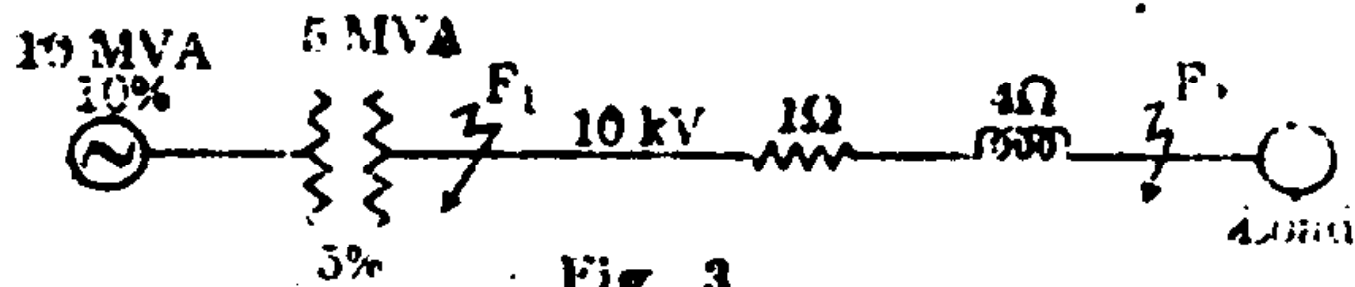

Fig. 3

- 3 (a) What do you understand by positive, negative and zero sequence impedances? Discuss these with reference to synchronous generators, transformers and transmission lines. Derive expressions for fault current by symmetrical components method for single line to ground fault.

b. S.

OR

- 3 (a) A 3 phase, 10 MVA, 11 kV generator with a solidly earthed neutral point supplies a feeder. The relevant impedances of the generator and feeder in ohms are as under

	Gen.	Feeder
Positive sequence impedance	$j12$	$j10$
Negative sequence impedance	$j0.9$	$j1.0$
Zero sequence impedance	$j0.4$	$j3.0$

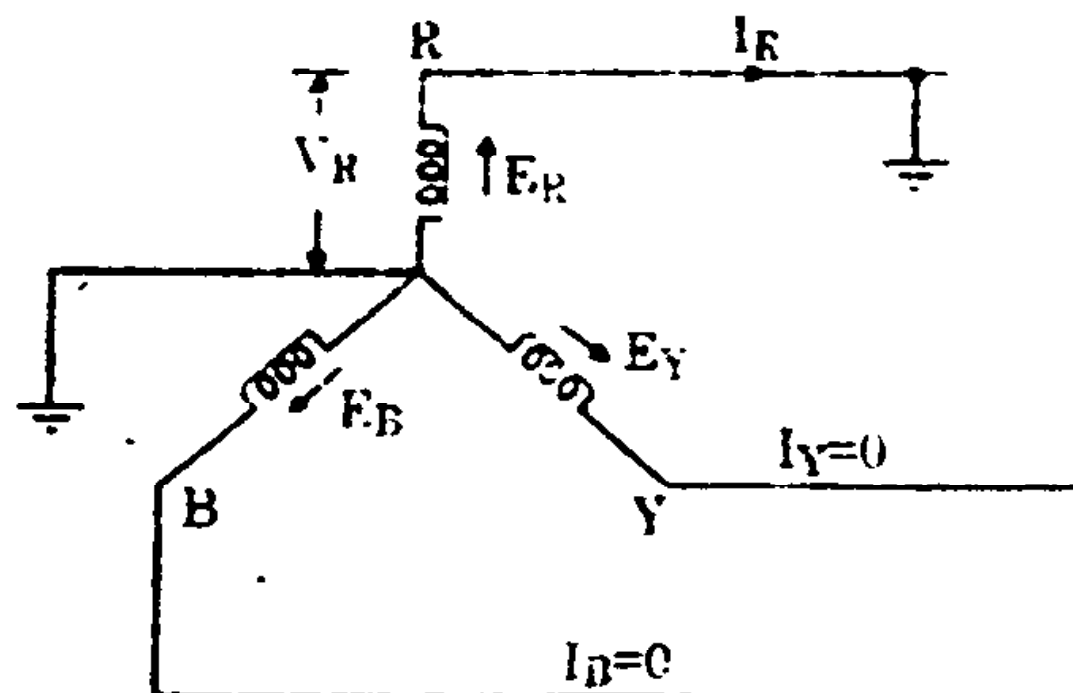

Fig. 4

If a fault one phase to earth occurs. On the far end of the feeder, calculate :

- (i) The magnitude of fault current
- (ii) Line to neutral voltage at the gen. terminal

12

(b) State Fortescue theorem.

4

- 4 (a) Derive the necessary equation to determine the fault current for a double line to ground fault.

10

(b) Draw a diagram showing interconnection of sequence networks.

6

OR:

- 4 Two 11 kV, 50 MVA, 3 phase alternators are connected in parallel. Each alternator has a reactance to positive, negative and zero sequence currents of 0.6 ohms, 0.40 ohms and 0.02 ohm respectively and has its neutral earthed through a resistance of 0.20 ohm. The alternators supply a substation through a feeder having impedances of $0.4 + j0.7$ ohm to positive and negative sequence currents and $0.7 + j30$ ohms to zero sequence currents.

A double line to ground fault occurs at the substation. Calculate (a) the fault currents (b) potential above ground attained by alternator neutrals.

16

- 5 (a) Derive static load flow equation. Discuss its characteristic and assumptions made to obtain modified SLFE.
- (b) How are buses classified in a power system.
- (c) How are system variables classified in a static load flow equation.

10, 3, 3

OR

- 5 (a) Compare the methods of load flow analysis.
- (b) Give a flow chart for a load flow study using Newton-Raphson method. Also discuss the Newton-Raphson method in detail.
- (c) How does the method get modified when PV buses are also present.

4, 8, 4