

4E2149

Roll No. : _____

Total Printed Pages : **4****4E2149****B. Tech. (Sem. IV) (Main / Back) Examination, June/July - 2013**
4EX2 Electrical Electronics*Digital*Time : **3 Hours**][Total Marks : **80**[Min. Passing Marks : **24**

*Attempt any five questions, selecting one question from each unit.
All questions carry equal marks. Schematic diagrams must be shown wherever necessary. Any data you feel missing suitably be assumed and stated clearly.*

Units of quantities used/calculated must be stated clearly.

Use of following supporting material is permitted during examination.
(Mentioned in form No. 205)

1. NIL2. NIL**UNIT - I****1 (a)** Perform the following operations using 2's complement :

(i) $(1ABC)_{16} + (1DEF)_{16}$

(ii) $(+43)_{10} - (-53)_{10}$

(iii) $(3E91)_{16} - (1F93)_{16}$

2×3**(b)** Derive the Boolean expression for a 2 input EX-OR logic gate to realize with two input NAND gate without using complemented variables. Also, draw the circuit diagram.**4****(c)** A 12-bit Hamming code word containing 8-bits of data and 4 parity bits is read out from memory. What will be the original 8-bit word if the 12-bit read out is as follows :

(i) 1100 1010 0110

(ii) 0011 0110 0101

3×2**OR****4E2149]****1****[Contd...**

- 1 (a) Explain how errors are detected using :
 (i) Check sums
 (ii) Block parity
 4
- (b) What is reflective code ? With the help of an example, explain the differences between the reflective and sequential code.
 4
- (c) A 16-bit data word given by 1001100001110110 is to be transmitted by using a fourfold repetition code. If the data word is broken into four blocks of four bit each, then write down the transmitted bit stream.
 8

UNIT - II

- 2 (a) Why ECL is called non-saturating device ? What is the main advantage accruing from this ? With help of relevant circuit diagram, briefly describe the operation of ECL OR / NOR logic.
 6
- (b) Show that in a totem pole TTL NAND gate, transistor Q_2 and Q_3 cannot conduct simultaneously.
 6
- (c) Why it is not recommended to leave the unused logic inputs floating ? What should be done to such inputs in case of TTL and CMOS logic gate families.
 4

OR

- 2 (a) The data sheets of a Quad two-input AND gate specifies the propagation delay and power supply parameters as ;
 $I_{CC} = 5.0mA$, $I_{CC_H} = 18mA$ (for all four gates); $I_{CC_L} = 32mA$ (for all four gates); $t_{p_{LH}} = 4.5ns$ and $t_{p_{HL}} = 5ns$. Determine the speed power product specification.
 10
- (b) What in a logic family, decides the fan-out, speed of operation, noise immunity and power dissipation.
 6

UNIT - III

- 3 (a) Write down the minterm and maxterm Boolean expression given by $f(A, B, C) = \pi 0, 3, 7$.
 8



- (b) Reduce $\pi M(1, 2, 3, 5, 6, 7, 8, 9, 12, 13)$ and implement it in universal logics.

8

OR

- 3 (a) Using the Quinn-McCluskey method of tabular reduction, minimize the given combinational signal output function.

$$f(A, B, C, D) = \sum M(0, 1, 5, 7, 8, 10, 14, 15)$$

8

- (b) Obtain the minimal POS expression for :

$$f = \pi M(0, 1, 4, 5, 9, 11, 13, 15, 16, 17, 25, 27, 28, 29, 31) \cdot$$

$$\cdot d(20, 21, 22, 30)$$

8

UNIT - IV

- 4 (a) If the CARRY GENERATE G_i and CARRY PROPAGATE P_i are redefined as $P_i = (A_i + B_i)$ and $G_i = A_i B_i$. Show that CARRY output C_{i+1} and SUM output S_i of full adder can be expressed as

$$C_{i+1} = (\overline{C_i} \overline{G_i} + \overline{P_i}) = G_i + P_i C_i \text{ and } S_i = (P_i \overline{G_i}) \oplus G_i$$

8

- (b) Design the following :

- (i) 32 : 1 MUX using two 16 : 1 MUX's one 2 : 1 MUX.
 (ii) 10 × 1K decoder using 8 × 256 decoder and additional logics.

4×2

OR

- 4 (a) Implement the following multiple outputs combinational logic circuits using 3 to 8 line decoder circuitry :

$$F_1 = \sum m(0, 1, 2, 6)$$

$$F_2 = \sum m(2, 4, 6)$$

$$F_3 = \sum m(0, 1, 5, 6)$$

8

- (b) If the minuend, subtrahend and BORROW-W bits are respectively applied to Augend, Addend and CARRY-W inputs of a full adder, prove that the sum output of full adder will produce correct DIFFERENCE output.

8



UNIT - V

- 5 (a) Determine the function performed by the circuit given in fig. 5 (a). Referring to circuit, write its count sequence if it is initialize at 0000. Also draw the timing sequence.

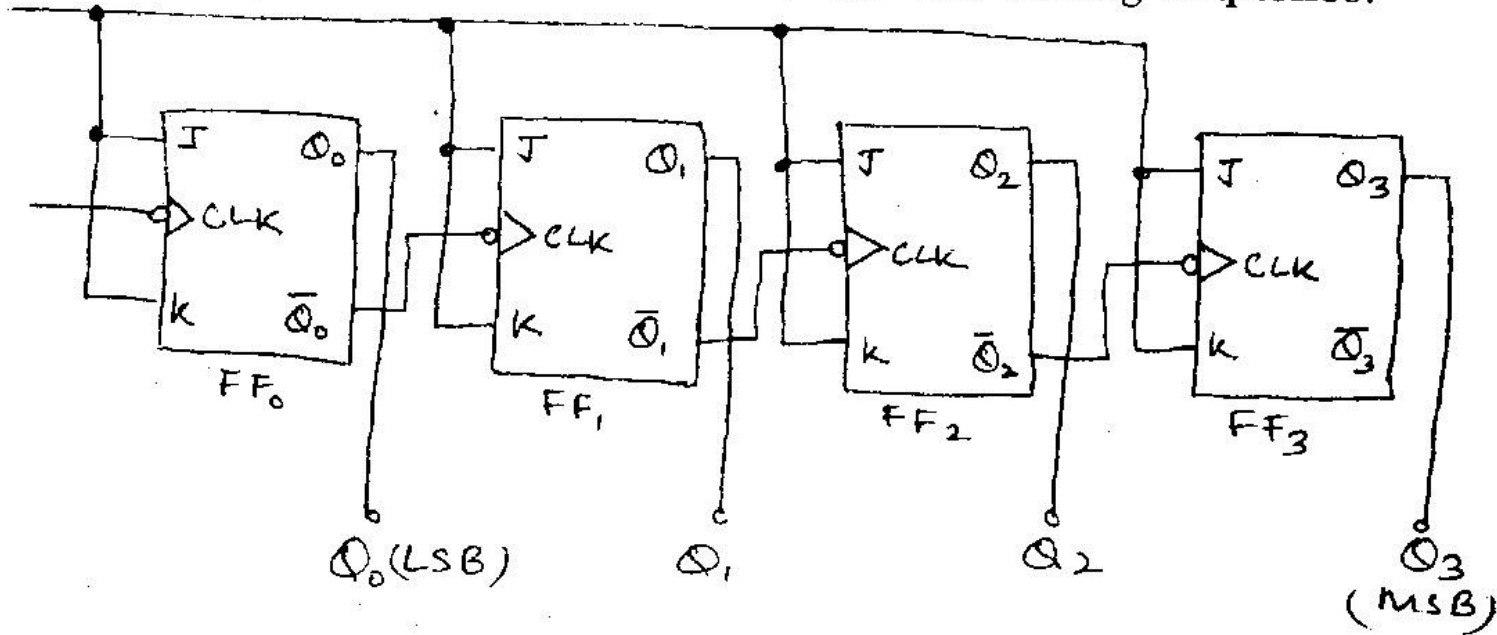

Figure 5 (a)

- (b) Why is the maximum usable clock frequency in case of a synchronous counter independent of the size of counter.

10

6

OR

- 5 The 100 KHz square waveform given in the figure 5 (b) is applied to clock input of flip flop given in figure 5 (c) and 5 (d). If the Q output is initialize at '0', draw the output waveform in two cases. Also determine the frequency of Q output in these two cases.

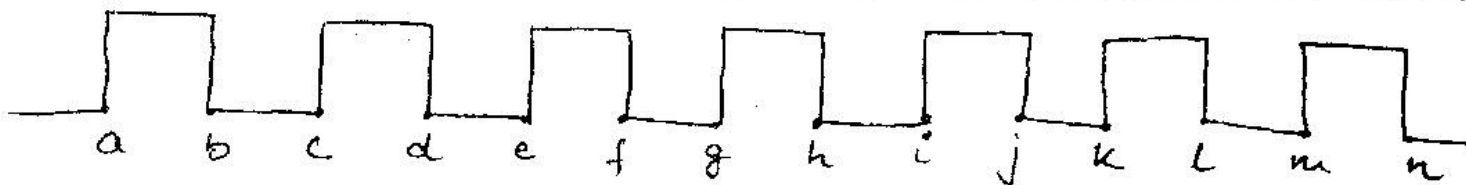

Figure 5 (b)

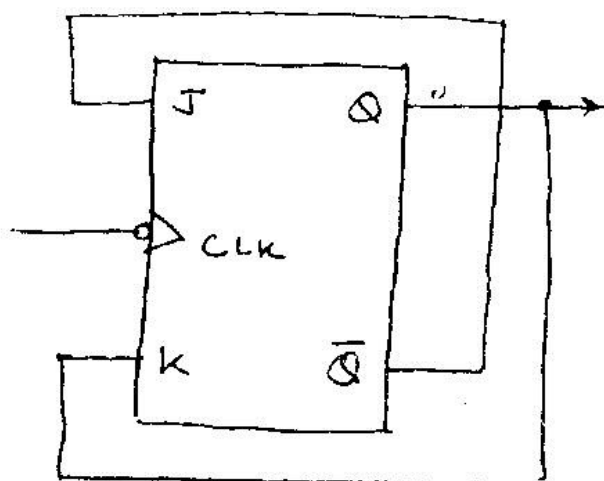

Figure 5 (c)

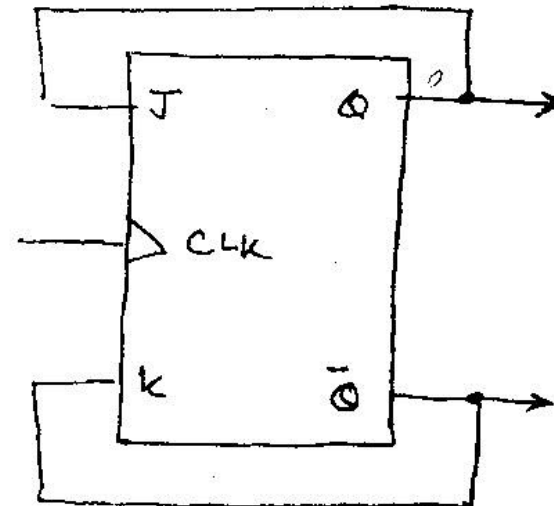

Figure 5 (d)

16

