

5E3256

Roll No. _____

Total No. of Pages : **3****5E3256****B.Tech.V Sem.(Main /Back)Examination Dec. 2012****Computer Science****5CS6.1 Advanced Data Structure****Common for CS & IT****Time : 3 Hours****Maximum Marks : 80****Min. Passing Marks : 24***Instructions to Candidates:*

Attempt any five question selecting one question from each unit . All Questions carry equal marks. Schematic diagrams must be shown wherever necessary. Any data you feel missing suitably be assumed and stated clearly. Units of quantities used / calculated must be stated clearly.

Use of following supporting material is permitted during examination.
(Mentioned in form No. 205)

1. Nil 2. Nil

UNIT-I

Q.1. (a) Explain the LLr, LRr, LLb, LRb imbalances in a Red-Black tree with example? (8)

(b) What is dynamic order statistics ? Explain the advantages of splay tree in representation of dictionaries. (8)

OR

Q.1 (a) Explain briefly the representation of 2-3 trees with example. Explain its insert & delete operations. (8)

(b) Explain Interval trees with the help of example. (8)

UNIT-II

Q.2. (a) Explain the features of "Adjust" algorithm used for adjusting the given sequence into a heap. Also analyse the algorithm. (8)

(b) Perform Extract_min operation in the following Fibonacci Heap. (8)

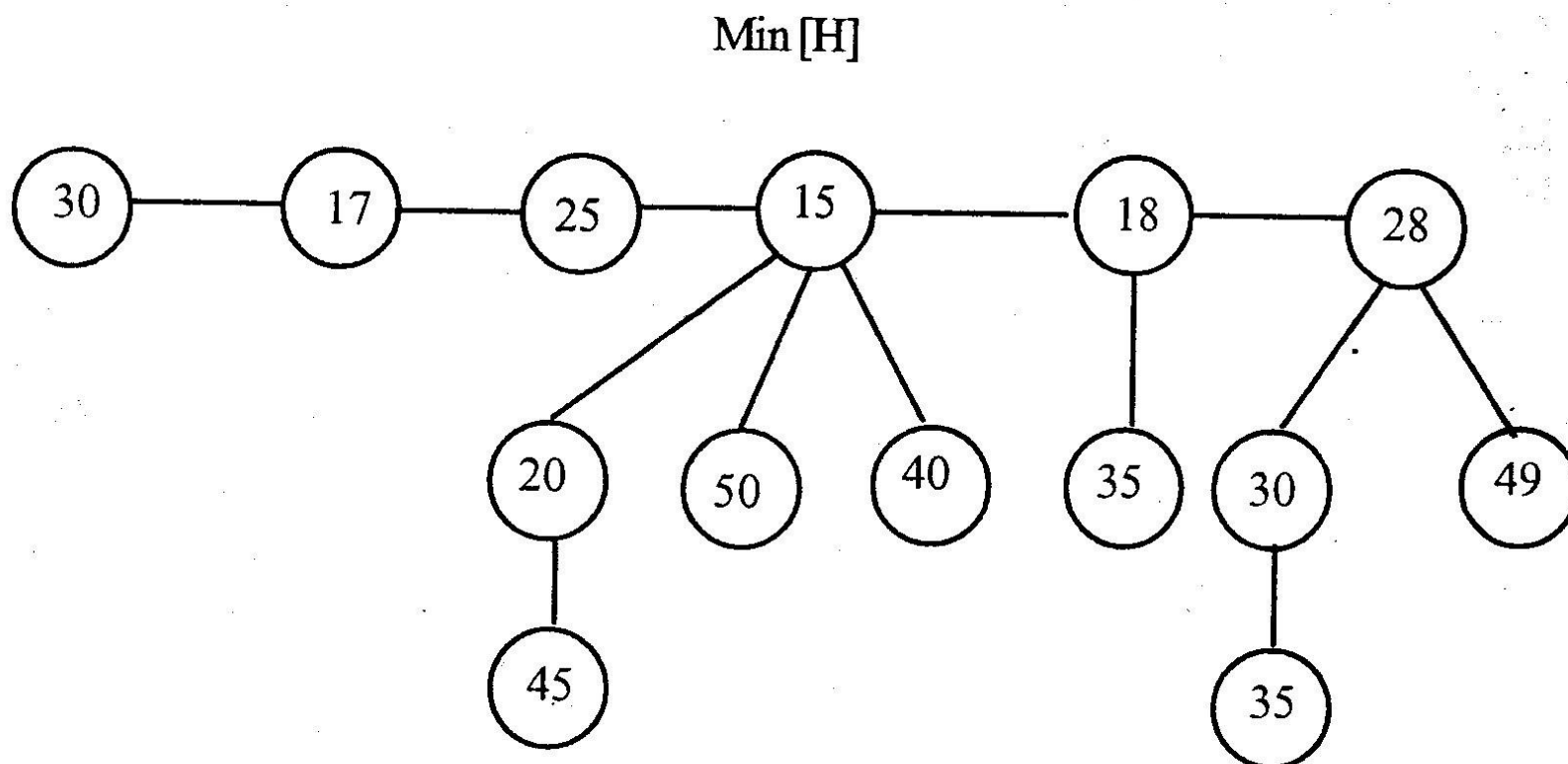

OR

Q.2. (a) Explain Binominal Heaps & its operation with example. (8)

(b) Write short notes on (any one) (8)

(i) 2-3-4 trees

(ii) Potential function of Fibonacci Heap.

UNIT-III

Q.3. Explain Ford Fulkerson Max flow algorithm with the help of example. (16)

OR

Q.3. Define these terms (any 2) (16)

(a) Isomorphic Components

(b) Connected Components & Articulation point.

(c) Cut vertices

(d) Planer & Dual graph

UNIT-IV

- Q.4. (a) Explain parallel merge sorter with the help of an example. (8)
- (b) Explain union - find problem for the implementation of disjoint sets. (8)

OR

- Q.4. Write short notes on (16)
- (a) Bitonic sorter with example
- (b) Zero-one principle

UNIT-V

- Q.5. (a) Explain Chinese Remainders theorem with the help of example. (8)
- (b) Write short notes on (8)
- (i) Modular Arithmetic
- (ii) Discrete Logarithms Computations.

OR

- Q.5. (a) Explain Euclid algorithm with the help of example. Find out GCD (73,31) using extended Euclid algorithm. (10)
- (b) Explain Division theorem with the help of an example. (6)
