

Code : 021202

B.Tech. 2nd Semester Exam., 2014

ENGINEERING GRAPHICS

Time : 3 hours

Full Marks : 70

Instructions :

- (i) All questions carry equal marks.
- (ii) There are **NINE** questions in this paper.
- (iii) Attempt **FIVE** questions in all.
- (iv) Question No. 1 is compulsory.

1. Answer the following questions (any seven) :

- (a) Write down two major differences between first angle and third angle of projection.
- (b) A circular lamina is perpendicular on VP and top view is a straight line. What will be its front view and side view?
- (c) Write down two main roles of key/critical points in describing intersection of surfaces.
- (d) Write down two major differences between isometric view and isometric projections.
- (e) What is an Archimedean spiral?

(2)

- (f) Describe the possible position of a triangular lamina so that projection of the triangular lamina will be a straight line in first angle of projection.
- (g) Show the various positions of cutting planes passing through a right regular cone so that (i) parabola, (ii) ellipse, (iii) hyperbola and (iv) circle may be obtained.
- (h) Describe the functions of the following AutoCAD commands :
 - (i) PLINE
 - (ii) ARRAY
- (i) If a semicircular thin sheet is folded to form a cone, then how will the front view of the cone appear?
- (j) If the apparent and the true inclinations of a line with HP are equal, then what will be the position of line?

2. Construct a parabola when the distance between the focus and directrix is 30 mm. Draw the tangent and normal at any general point on the curve.

3. A straight line CD is inclined at 30° to the VP and 45° to the HP. Its LHSV measures 45 mm. The midpoint P of the line is 55 mm in front of the VP and 50 mm above the HP. Draw the three views of the line and find its true length.

(3)



4. A pentagonal pyramid of base 20 mm and height 50 mm has its triangular face in the VP with a shorter side inclined to the HP at 30° . Draw its projections.
5. A square prism, base 45 mm, side axis 90 mm long, stands on the HP with its axis vertical, such that its faces are equally inclined to the VP. The prism is cut by a plane, perpendicular to the VP, inclined at 60° to the HP and passing through a point on the axis of the prism 65 mm above the HP. Draw its projections and the true shape of the section.
6. A pentagonal prism of base side 30 mm and axis length 60 mm is resting on HP on its base with a side of base parallel to VP. It is cut by a plane inclined at 35° to HP and perpendicular to VP and meets the axis at a distance 35 mm from the base. Draw the development of the lower portion of the prism.
7. A right circular cone of base diameter 80 mm and altitude 90 mm has its base horizontal. A cylinder of diameter 40 mm with its axis horizontal and 30 mm above the base of the cone penetrates the cone, the axes are intersecting at right angles. Show the curves of intersection in the plan and elevation.

(4)

8. Draw the front view, top view and left-hand side view of the following object (Fig. 1) :

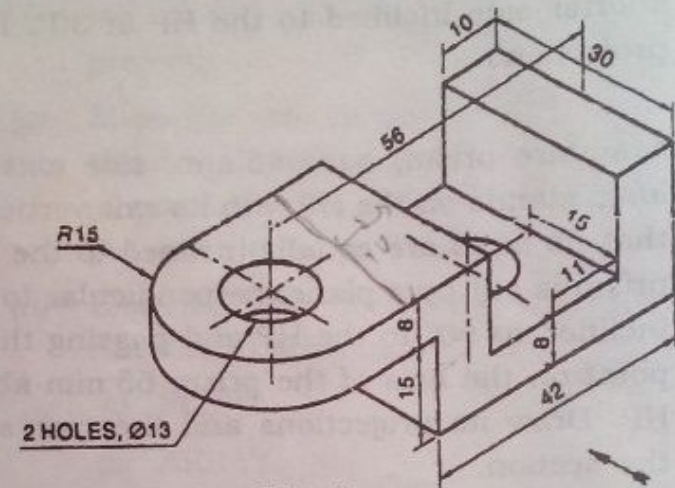

Fig. 1

9. Draw the isometric view from the following orthographic views (Fig. 2) :

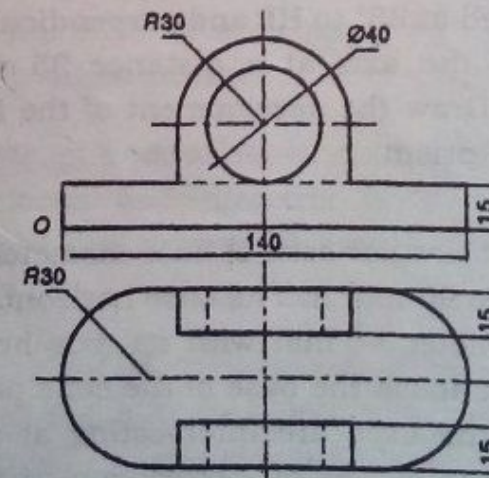

Fig. 2
